

Centrifugal Barrel Finishing Machine



HS30 *[éis]* ACE



PREMIUM
DURABILITY
3 YEAR
WARRANTY

HS30-10G

An Industry Standard, Created by Tipton

Patent

US3233372 JP7598628 WO2024214135

Made in Japan

Tipton originated centrifugal barrels.

The theory of centrifugal flow was developed in 1961 by the late Hisamine Kobayashi, the founder of Tipton Corp., and has been patented in seven countries around the world. Since then, centrifugal barrels have been used around the world as finishing machines for automotive, electronic, and medical parts. Today, it has become the established industry standard, with 170 patents related to Tipton's centrifugal barrels.



Principle of process by centrifugal flow

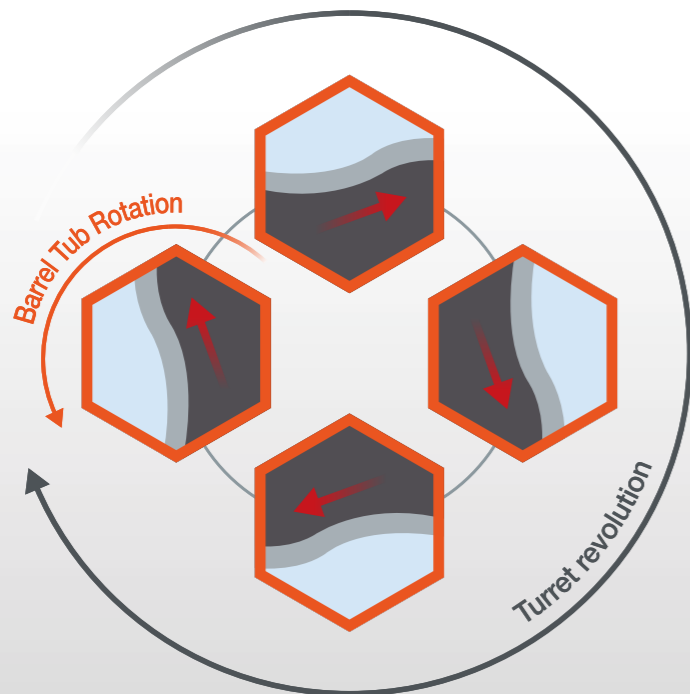

Barrel tubs with a hexagonal cross-section are placed on a rotating turret. Each barrel tub rotates on its axis in the opposite direction to the turret rotation (revolution). This planetary rotation motion allows the workpiece to slide on the mass surface and be polished.

The processing capacity is extremely high among other barrel finishing machines and is 30 to 60 times greater than that of a rotating barrel.



HS30 ACE [éis]

Pursuing ease of use based on extensive sales results.

Equipped with functions carefully selected based on the sales of over 10,000 units during the 60-year history of centrifugal barrels. Dramatically renovated according to our customers' needs.



Benefit and application

Precision finishing

Short-time finishing

Applicable to all Metals (Iron, Nonferrous, Alloy), Plastic, Ceramic, Jewelry, Glass, and so on for the purpose of Deburring, Descaling, Rough Finishing, and Mirror Finishing.

Try our finishing condition selection service. Our experienced staff will select the optimum media compound suitable for the processing purpose.



Operability

Adoption of a large touch panel.
Multi-stage operation setting and operation condition registration are available.

▶ Multi-stage operation setting

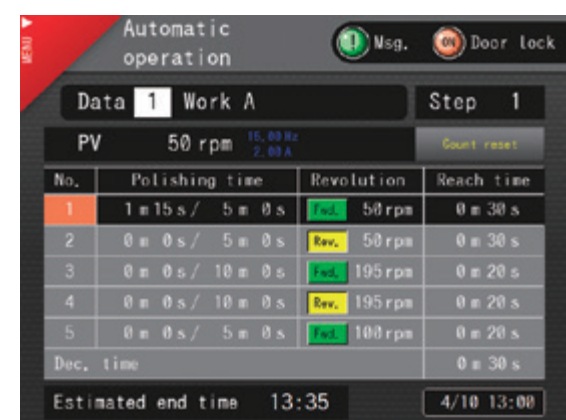

Up to five levels of multi-stage operation can be set. Finishing conditions can be freely customized, increasing the range of finishing variations.

Setting for measures against chips/cracks

Chips and cracks are prevented by gradually increasing the speed.

Setting for surface roughness level

The process from rough finishing to final finishing can be performed continuously by gradually reducing the speed.

Setting for long-time finishing

Temperature rise in the tub is suppressed by automatically repeating operation and stop (cooling).

Setting for uneven finishing prevention

Variations in finishing of a large workpiece due to rotation directions can be prevented by repeating forward and reverse rotations.

▶ Operation condition registration

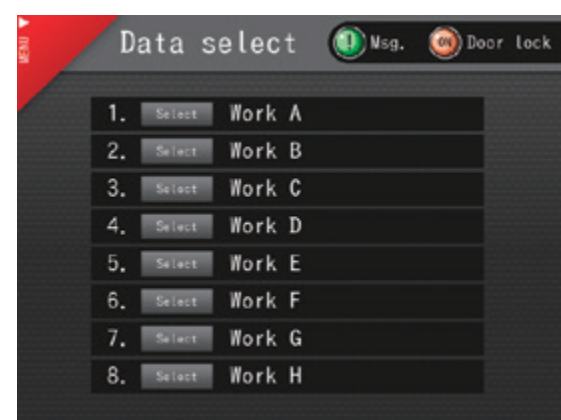

Up to eight operation conditions can be registered. Even if there are many types of workpieces, detailed operation settings for each type can be recalled easily. This prevents defective processing due to incorrect settings.

Fixed-position stop of barrel tub

Feed operation can be performed with one button when loading/unloading the barrel tub. There is no need to adjust the fixed position, and the barrel tub automatically stops at the work position.



Maintainability



Adoption of easily replaceable lining parts and highly durable paint that lasts for extended periods of time even in wet areas.

Long-awaited by the industry!
Quickly replaced in just one minute!

▶ Barrel tub with replaceable lining Patent | JP7598628



Requiring no repairs by the manufacturer

The lining can easily be replaced by the user. Even if the lining is worn out, there is no need to wait for the manufacturer to repair the barrel tub.

Lining replaceable any number of times

Since the rubber baking process is not required for replacement of the lining, the metal part of the barrel tub does not deteriorate. This means the barrel tub can be used for years by replacing the lining as many times as required.

Seamless smooth lining

Since the rubber is press-molded, the inner surface is finished seamlessly and smoothly. This prevents a workpiece and media from remaining or getting caught.

Freely selectable lining materials and shapes

The material, hardness, and thickness of the lining can be changed according to customer needs, and the surface can be made uneven or slit as needed.

Workpiece adhesion prevention type.

Adoption of highly durable paint

Newly adopted paint resistant to compounds and synthetic oils. This protects the machine from corrosion for an extended period of time. The coating film is maintained even if soaked in the degreasing compound for more than one month.

*This varies depending on the usage environment.

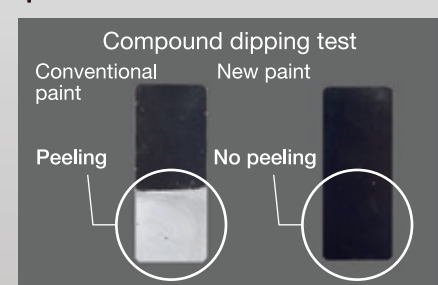

Safety

Side sliding door, door interlock function, and control by 24 VDC prevent injury.



▶ Side sliding door

Adoption of a side sliding door that can be opened and closed easily without the need for large force. Unlike conventional vertical operation doors, there is no danger of hands being caught by falling doors.

▶ Door interlock function

The centrifugal barrel is structured so that heavy objects rotate inside. For safety reasons, all rotational motions including feeding of the barrel tub are locked while the door is open. There is no risk of human contact with the rotating part.

Control voltage 24 VDC

Low voltage reduces the risk of electric shock.

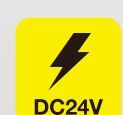

With casters/adjusters

The machine can be moved and installed easily and safely even in tight spaces without using a hoist or hand lift. It is also resistant to corrosion around the bottom.



Specifications

Model	HS30-10G
Relative centrifugal acceleration	9G
Barrel capacity	7.1 L x 4 tubs
ID of Barrel Tub	170 mm (Diagonal line) x 284 mm (Depth)
Motor capacity	2.2 kW
Machine size	960 mm (W) x 920 mm (D) x 1570 mm (H)
Footprint	1120 mm (W) x 920 mm (D)
Machine weight	Approx. 500 kg

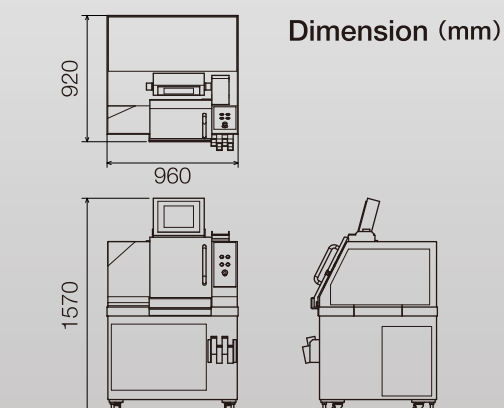

HS30 ACE [éis]

Options

Rich options provide better operation and higher functionality.

◆ Safety pack

Three-piece set of Barrel Tub Lock Detection + Rotation Speed Feedback Function + Signal Tower

Barrel tub lock detection



The sensor automatically detects whether the barrel tub is properly fixed to the device at the start of finishing. This prevents the barrel tub from falling off, so the machine can be used with peace of mind.

Patent | WO2024214135

Rotation speed feedback function



The centrifugal barrel loses the finishing capability by as much as 20% when the rotation speed decreases by just 5%. In order to maintain stable finishing quality, the rotation speed is measured by the sensor and automatically corrected if there is a difference with the preset rotation speed.

Signal tower



The operation status of the machine is announced by the three-color LED and buzzer.

◆ Customization of barrel tub

One-point fixing lid

Thank to the three-way arms, the lid can be fixed with only one center bolt. This not only makes it possible to quickly attach and detach the lid but also reduces the risk of water leakage during operation because the same tightening force applies to three locations simultaneously.

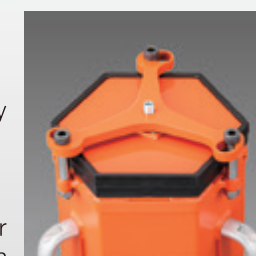

Stainless steel barrel tub

This prevents contamination from rust, paint, etc.



Small capacity barrel tub

Two 2.6L barrel tubs are installed. Ideal for small quantities and minute workpieces. In addition, since the total weight of tubs is reduced, the burden on the operator can also be reduced. Custom order for barrel tubs of other capacities are also available.

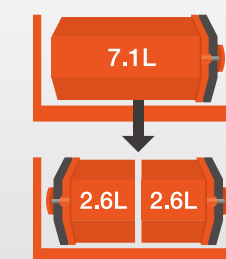

Simultaneous fixation of tub and lid with a clamp

One clamp lever fixes both the barrel tub and the lid simultaneously. Since it requires only one action, the time required for attaching and detaching can be reduced by approximately 80%.

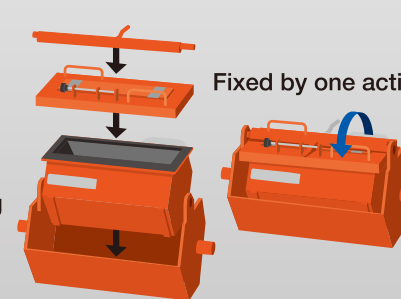

*We also offer high-durability urethane lining (non-replaceable).



Tipton Corp.

<https://www.tipton.co.jp>

Head Office	3-19-21 Toyoda, Minami-Ku, Nagoya, Aichi Prefecture 457-8566 Japan Tel : +81-52-692-6666 Fax : +81-52-692-9445
Headquarter-Sales	3-19-21 Toyoda, Minami-Ku, Nagoya, Aichi Prefecture 457-8566 Japan Tel : +81-52-692-7175 Fax : +81-52-692-0249
Tobishima Factory	3-25-1 Odakara, Tobishima-Mura, Ama-Gun, Aichi Prefecture 490-1438 Japan Tel : +81-567-56-7500 Fax : +81-567-56-7513
Tipton USA Inc.	2450 W Broadway Rd. Suite 108, Mesa, AZ 85202, USA Tel : +1-480-795-2647

Quality Assurance Section
for Product Quality

Tel : +81-567-56-7503
Fax: +81-567-56-7516

Engineering Section
for Machine Maintenance

Tel : +81-567-56-7504
Fax: +81-567-56-7514

E-mail

sales-department@tipton.co.jp
sales-department@tiptonusa.com
(North America)

Note) All unapproved reproduction of a report a photograph, etc are forbidden found in this catalog.



This catalog is printed using environment-friendly vegetable ink.